

Question

What is the so-called “reverse recovery time” (t_{rr}) specification of diodes?

Answer

Ideally, a diode is (a) a perfect conductor when it is forward biased, (b) a perfect insulator when reverse biased, and (c) the transition from conductor to insulator is instantaneous upon a forward bias/reverse bias switch.

Practical diodes don't display these ideal characteristics, and this question is related to the transition (switching) time from conduction to open circuit when the bias is reversed. The figure below shows what happens when the diode bias is switched from forward to reverse. At the switch time, the current reverses and stays at a constant level for a period of time called the storage time, t_s . During this time the diode acts essentially as a short circuit. Then the current decreases to the reverse leakage current value. This latter time is called the transition time. The sum of the storage and transition times is the reverse recovery time. It depends on the forward current, and data sheets give the reverse recovery time along with the test conditions.

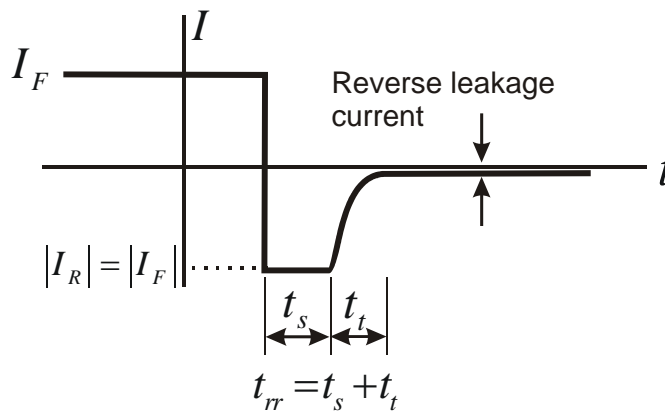

Reverse recovery time t_{rr} of a diode

Why does a diode behave this way? When pn junction is forward biased, a large number of electrons are injected into the p -material, and a large number of holes are injected into the n -material of the pn junction. When the diode is then reverse biased, these stored minority carriers must return to the opposite material. The time it takes for the electrons to move from the p -material back to the n -material and the holes to move from the n -material to the p -material is the storage time, and is determined by the geometry of the pn junction. Once this migration is complete, the electrons diffuse to, and recombine at the anode, and the holes diffuse to and recombine at the cathode until there are no more of the original stored carriers left. This time is the transition time, and is determined by the geometry and doping levels of the p - and n -materials.

The reverse recovery times for pn junction diodes are a few microseconds for general-purpose rectifier diodes such as the 1N4001. When a diode is employed to rectify a

60 Hz voltage in a power supply, a reverse recovery time of 1 microsecond is irrelevant. However, when the diode is used as a switch in a circuit that runs at 100 KHz, then 1 microsecond is a substantial part of the conduction cycle, and the diode will dissipate significant energy. In switching applications such as DC-DC converters this can seriously impact efficiency. By manipulating doping levels and junction geometry one can manufacture semiconductor junction rectifiers with much smaller reverse recovery times. For example, the industry standard 1N4933 fast rectifier has a reverse recovery time of 200 ns. For small-signal (as opposed to power rectification) applications *pn* junction diodes can be made quite fast—the widely used 1N4148 small-signal diode has a reverse recovery time of 4 ns. However, all *pn* junctions have by necessity stored minority carriers when forward biased, so there are limits on what can be done. Additionally, the faster speed comes at the expense of higher forward voltage drop and higher reverse leakage currents.

For really small switching times, Schottky barrier diodes are used. These diodes are not *pn* junctions, but consist of a semiconductor-metal junction, and there are no stored minority carriers. Switching times can be as small as a few hundred picoseconds. This is very useful when protecting MOS devices, and in lower level switching and steering applications. Apart from fast switching times, Schottky diodes also have the desirable quality of low forward voltages. This makes them attractive for power rectifier applications.

Description	General Purpose Rectifier	Fast Switching Rectifier	Small Signal Diode	Schottky Diode
Sample Device	1N4001	1N4933	1N4148	ZC2800
Maximum DC/Average Forward Current	1 A	1 A	300 mA	15 mA
Maximum Reverse Voltage	50 V	50 V	75 V	70 V
Reverse Leakage Current @ 25 °C and $V_R = 20$ V	50 nA	200 nA	5 nA	200 nA
Forward Voltage	~0.7 V	1 V @ $I_F = 1$ A	1 V @ $I_F = 10$ mA	0.41 V @ 1 mA
Reverse Recovery Time	2 μ s	200 ns	4 ns	< 1 ns
Cost	20 cent	15 cent	25 cent	100 cent

Some characteristics of general-purpose/fast rectifier and general-purpose/Schottky diodes.